

THE OLYMPIC INSULATED PANEL FASTENER

- 100% AMERICAN MADE
- FAST, ONE STEP INSTALLATION
 - NO PREDRILLING NEEDED
 - NO PLATES NEEDED
- LOW PROFILE PANCAKE HEAD DOES NOT “TELEGRAPH” THROUGH COVERING LAYER
- EXTREMELY HIGH PULLOUT AND PULL THROUGH STRENGTH
- REMOVABLE – PERFECT FOR TEMPORARY WORK OR INSTALLATION ERROR
- ELIMINATES JARRING AND DAMAGE CAUSED BY A HAMMER AND NAIL

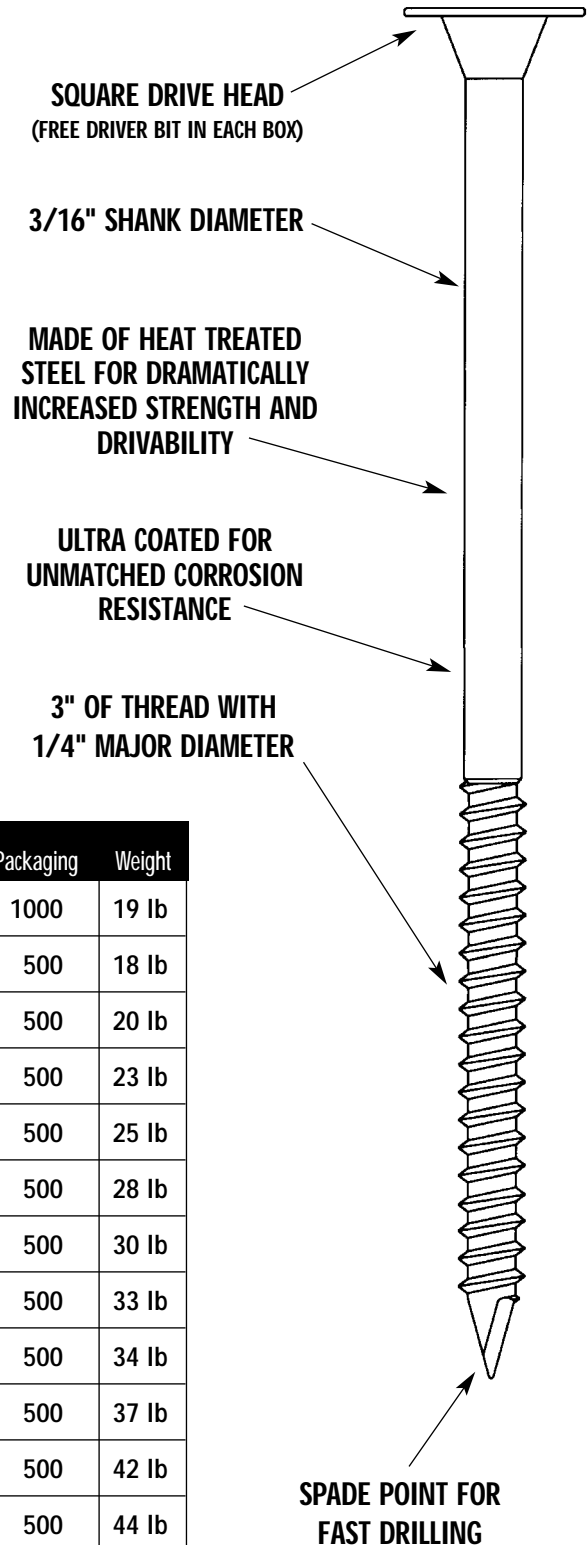

PHYSICAL DATA	Cat. No.	Length	Thread Length	Packaging	Weight
Thread Diameter: .240 Shank Diameter: .190 Head Style: Pancake head with internal square drive	SIP158	1½"	FULL	1000	19 lb
	SIP004	4"	3"	500	18 lb
	SIP412	4½"	3"	500	20 lb
	SIP005	5"	3"	500	23 lb
	SIP512	5½"	3"	500	25 lb
	SIP006	6"	3"	500	28 lb
	SIP612	6½"	3"	500	30 lb
	SIP007	7"	3"	500	33 lb
	SIP712	7½"	3"	500	34 lb
	SIP008	8"	3"	500	37 lb
	SIP009	9"	3"	500	42 lb
	SIP010	10"	3"	500	44 lb
	SIP011	11"	3"	500	47 lb
	SIP012	12"	3"	500	50 lb
SIP013	13"	3"	500	52 lb	
SIP014	14"	3"	500	53 lb	